

# PALLMANN

## Double Stream Mill PSKM

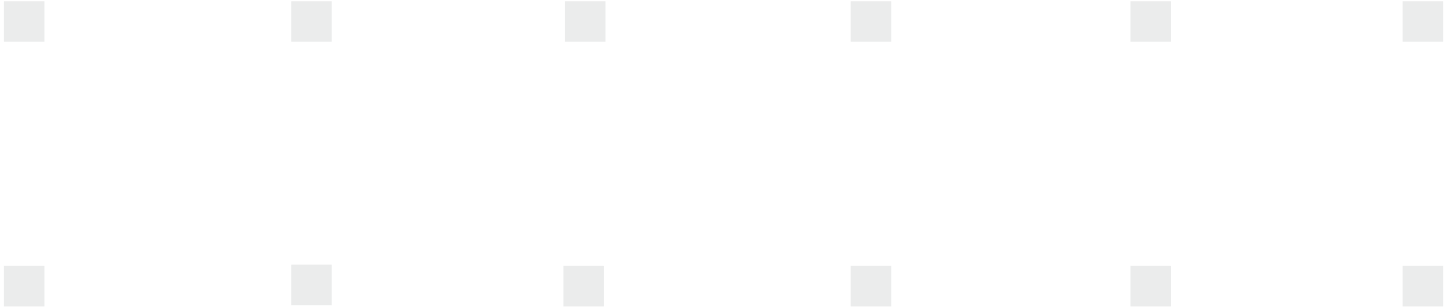

# Double Stream Mill PSKM

Double Stream Mills, type PSKM are airswept mills for gentle pulverizing of dry or moist, soft to medium hard materials. They are used for fiberizing of cellulose materials, wood and annual plants.

They ensure cool grinding at high throughput capacities with narrow particle size distribution. Typical materials to be processed are:

## Chemical Products

Ammonium nitrate, aluminum sulfate, magnesium, washing and detergent powders, soda, fertilizer salts, alkali salts, Glauber's salt, crude phosphate, insecticides.

## Foodstuff

Farinaceous products, legumes, powdered milk, gelatin, lactose, dextrose, glucose, spices.

## Feedstuff

Grain debris, presscakes, fishmeal.

## Fiberization

Wood flakes, planer shavings, sawdust, wood flour, annual plants, tobacco stems and ribs, cellulose.

## Pharmaceuticals

Drugs, ergot, cinchona bark, roots, antibiotics.

## Minerals

Gypsum, talc, graphite, chalk, bauxite, limestone, anhydrite, kaolin, asbestos

## Dyings and pigments

Organic and inorganic pigments, iron oxide, ochre.

## Plastics

Polyvinylchloride, polystyrene, phenol resins.

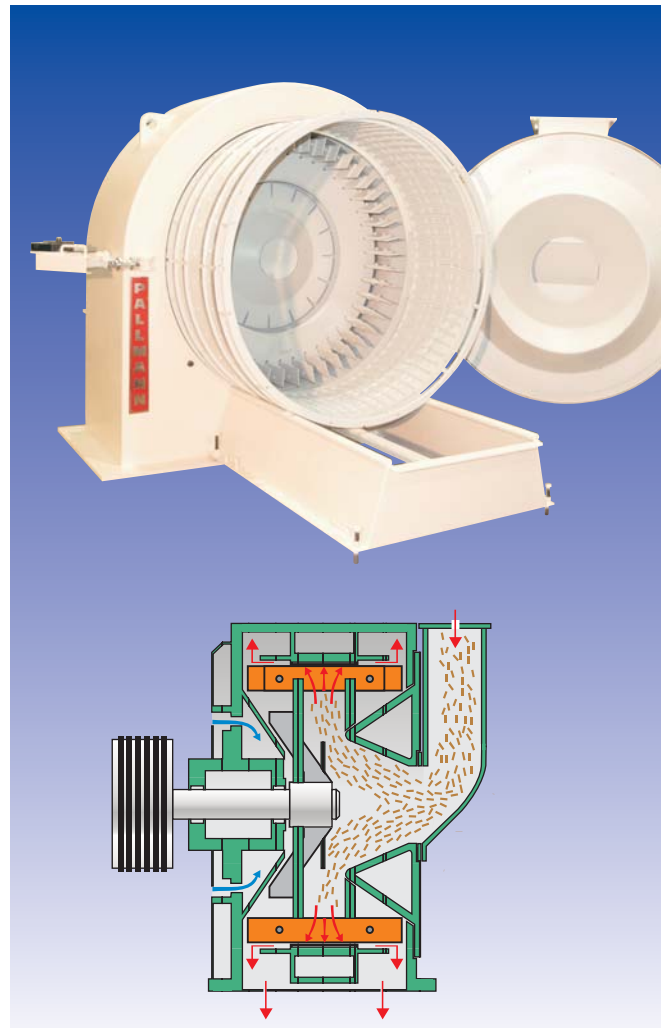

Double Stream Mills, type PSKM are built for tough around-the-clock operation. Heavy thick walled machine housings in fabricated design and a generously dimensioned bearing and drive arrangement guarantee smooth operation and a long service life. The bearing and drive system is flanged to the machine housing and can be easily exchanged as a compact premounted unit. The rotor is carefully stress relieved and electro dynamically balanced for smooth vibration-free operation. The grinding chamber is easily accessible through a large front door. As a standard a safety door locking allows only access to the grinding chamber at stand still of the rotor.

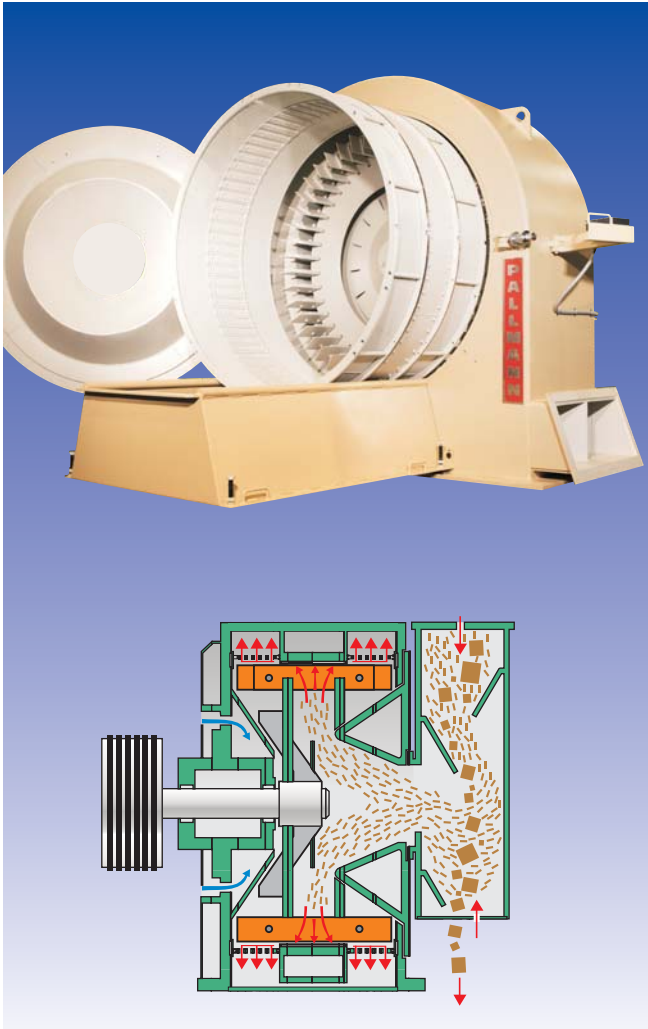

The Double Stream Mill, type PSKM is supplied in its standard version with finished product discharge straight down. A special housing design with integrated product collecting box and lateral product discharge is available. This option allows installation of the machine without any additional support frame or costly concrete foundation and pit. As a standard item, the scope of supply includes a slide to easily remove the grinding ring from the machine to the front. Additional lifting devices and dismantling of the impeller are not needed. Downtime for maintenance is essentially reduced because of this option for easy and quick wear parts exchange.

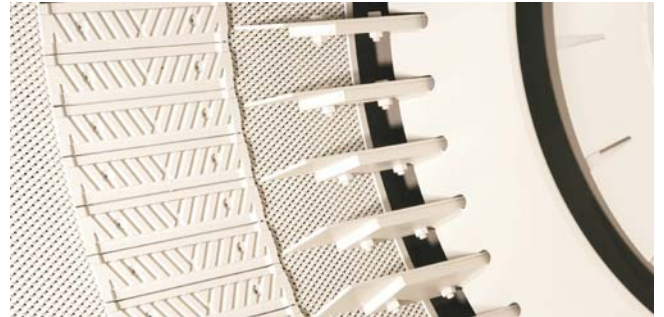

### Grinding and Sifting in a single Operation

With the PALLMANN Double Stream Mill the feed material is reduced through a new, pioneering principle. The fan effect of the multiple wing impeller pulls the feed material centrally into the grinding chamber after passing through a feed chute or a special feed chute designed as a gravity separator for heavy material. A specially designed material guiding cone distributes the material evenly on the periphery and the entire width of the grinding track. The impeller, rotating at high speed, produces high air turbulence between the impeller wear plates and the serrated profile of the grinding track. The double stream guides the feed material through intensive turbulence in an axial direction or in the cross stream depending on the profile used on the grinding track. The material is reduced in the high velocity air stream by repeated impact on the impeller wear plates and the grinding track profile. Through the air guide and within the flow channels of the grinding track a cross-stream sifting is achieved. Discharge of the finished product takes place only after the dragging force of the air exceeds the kinetic rebound energy applied to the particles. In the area of this actual flow, the percentage of mechanical friction is extremely small resulting in an extended service life of impeller wear plates and refining elements.

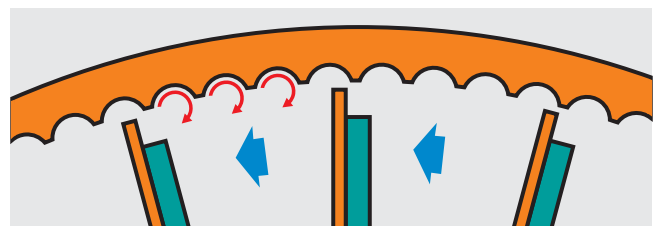

## PROVEN TECHNICAL CONCEPTS

### Different grinding profiles for each requirement

Size reduction is done exclusively on the central grinding track which is resistant to wear. The screen rings at both sides of the grinding track work as a subsequent sifter. By changing the screen sizes and many possible variations in the grinding path profile, the machine can be rapidly and easily adjusted to the desired degree of grinding. In addition, various wing beater wheel designs are available. Screen rings and grinding path elements can be easily replaced.



### Wide grinding tracks without screen rings

Special wide grinding tracks are used for coarse and fine preparation of moist and dry materials. A variety of different grinding track profiles are available which can be bolted down onto the grinding track. The wide grinding track is divided in three equal sections allowing easy adjustment of the total grinding track profile to changing feed material conditions or finished product requirements.

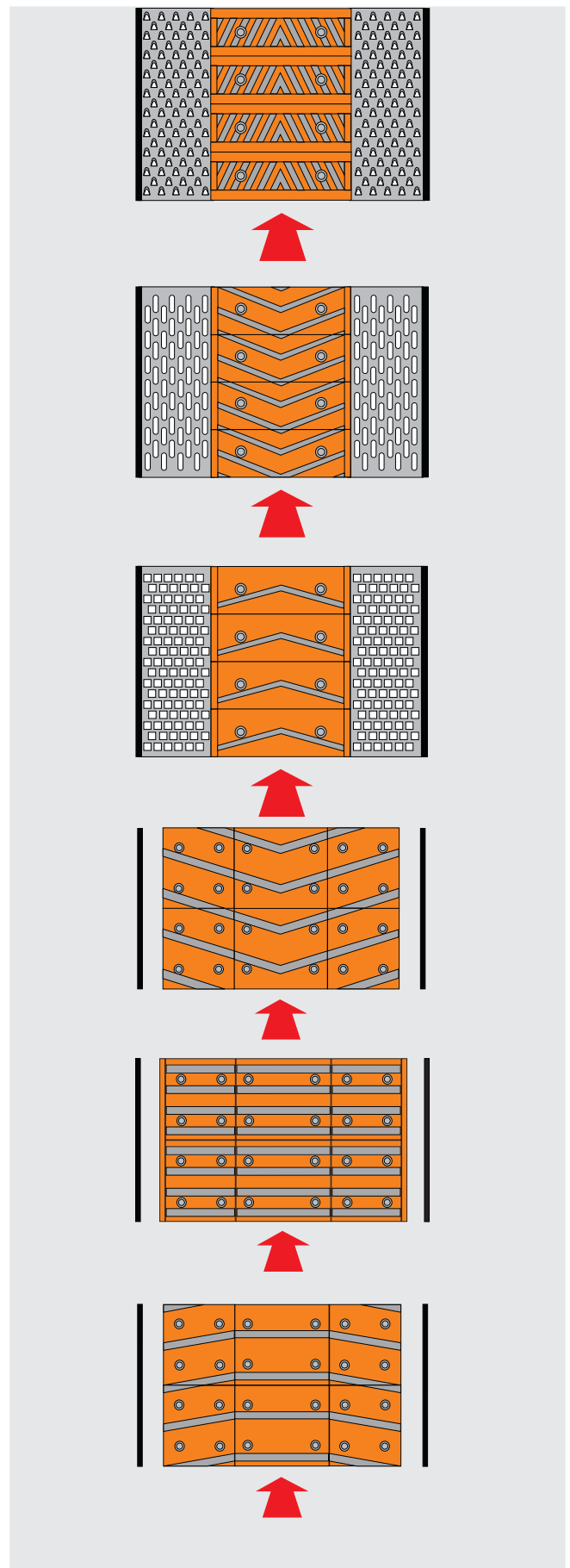
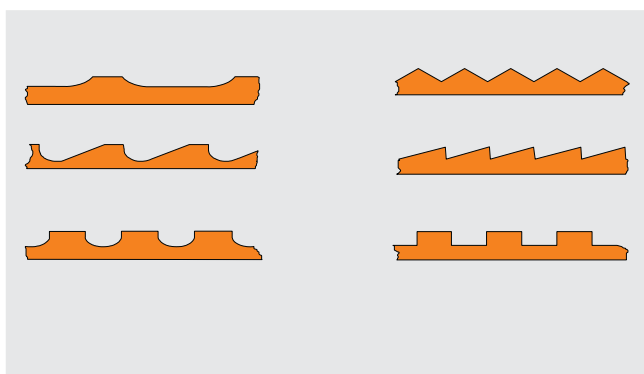

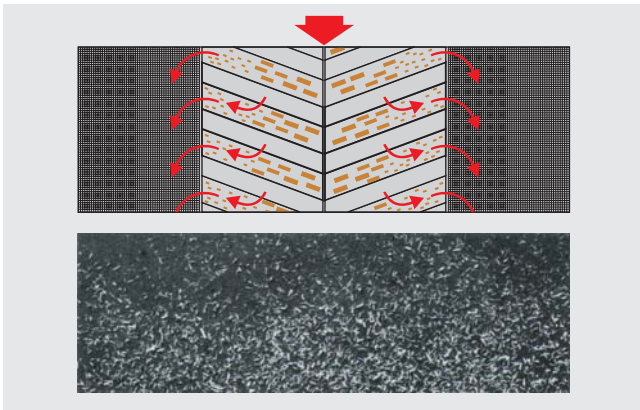

### Example: Into the V

Immediately after the feed material has been reduced on the grinding track, the fine particles are discharged through relatively coarse screen rings positioned on each side of the grinding track just by the air flow generated by the fast rotating impeller. Through adjustment of the air flow, selection of the grinding track profile and selection of the mesh size of the screen rings, the degree of preparation can be controlled as desired. These adjusting possibilities allow easy adaptation of the PALLMANN Double Stream Mill to the material quality required for different applications. Working into the V generally means a finer finished product.

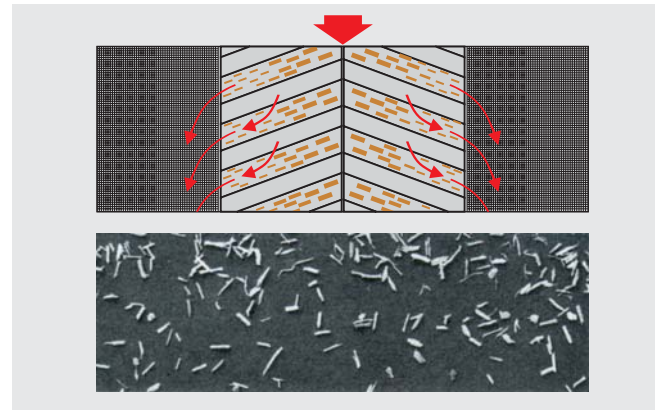

### Example: Out of the V

The optimum relation between dimensions of grinding track and screen surface, width of the impeller wear plates and installed motor power results in a high throughput capacity and grinding efficiency of the PALLMANN Double Stream Mill, combined with a minimum specific power requirement. Working out of the V means reduction of the retention time of the feed material on the central grinding track resulting in a coarser finished product.

### Adjustment of Fineness

By changing the height of the wear plates (dimension b) the distance to the grinding track (dimension c) can be adjusted as per requirement. Standard c-distances are 2, 4, 6, 8 and 10 mm.

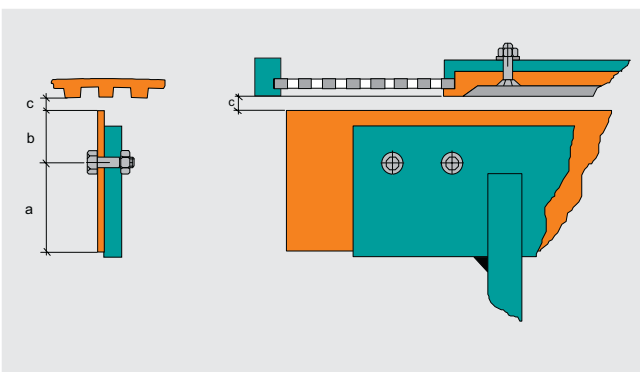

### Decisive advantages:

- Homogeneous material preparation
- Low specific power requirement
- High throughput capacity
- Adaptable for different infeed materials
- Easy adjustment of required fineness
- Easy exchange of wear parts
- High machine availability
- Very low maintenance cost

## PERFORMING SYSTEMS

### Proper installation guarantees optimum machine efficiency

Double Stream Mills, type PSKM should always be fed by vibratory feeders in order to make sure, that a uniform feed rate and optimum use of the installed electric power can be achieved. Between the vibrofeeder and the feed chute of the mill, it is recommended to install either a self cleaning drum magnet or a cascade feed chute with integrated drawer type permanent plate magnets which can be cleaned in regular intervals during operation. Installation of an air gravity separator is recommended to separate heavy foreign matters.

The air flow generated by the Double Stream Mill should be taken care of, by installing an aspiration system with dust collector.

The Double Stream Mill can be installed on a flat concrete floor if lateral product discharge has been chosen, or on a steel frame or on concrete foundations with a discharge pit if you decide for standard design with product discharge straight down.

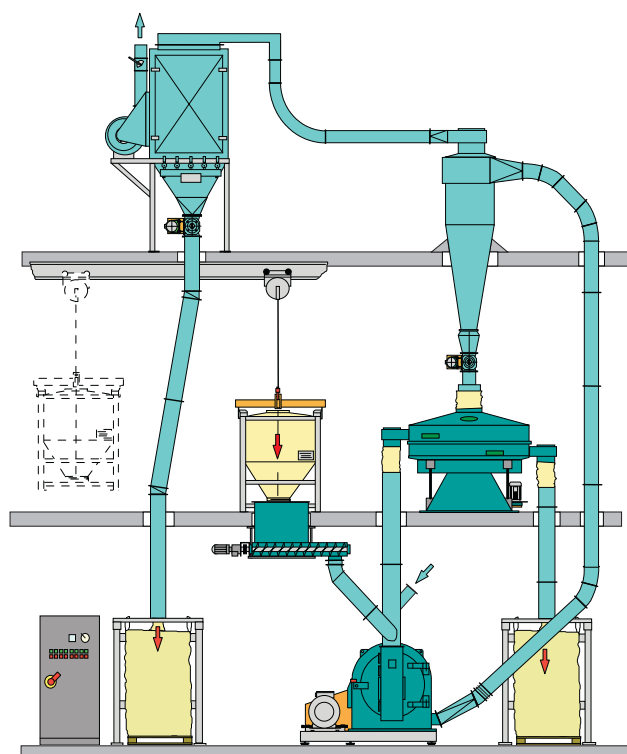
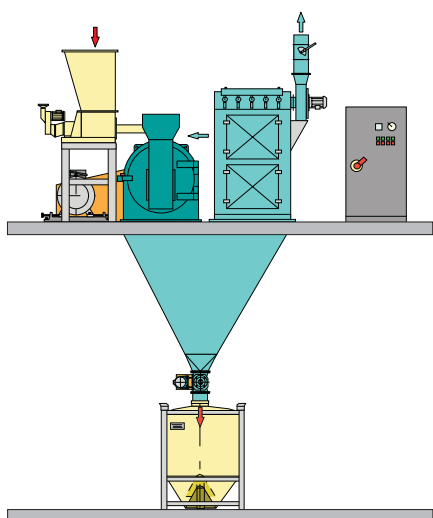
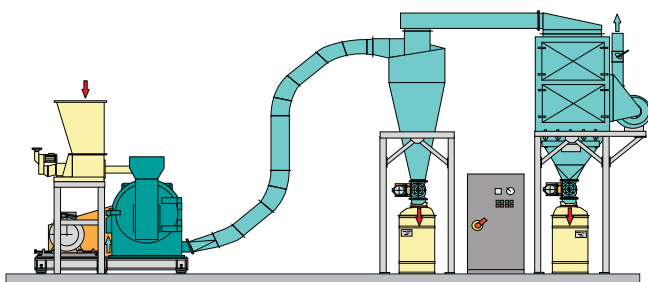

## Technical data:

Type	PSKM	6-350	8-460	10-530	12-600	14-660	15-720
Scale-up factor	F=ca.	0.6	1.0	1.3	1.6	2.3	3.4
Diameter of the grinding track	mm	600	800	1000	1200	1400	1500
Width of the grinding track	mm	120	150	180	210	230	250
Width of the screen rings	mm	2x100	2x140	2x160	2x180	2x200	2x220
Net weight machine without motor	approx. kg	650	1200	1800	2800	3800	4700
Shipping space machine only	approx. m <sup>3</sup>	1.0	1.8	3.5	5.5	8.0	11.0
Recommended motor	kW	55-75	90-110	132-200	200-315	250-400	315-500
Air displacement of machine	approx m <sup>3</sup> /min	75	100	130	150	200	250

### Standard version with bottom discharge

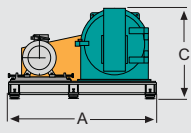
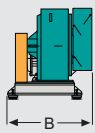

A	mm	1900	2700	2900	3300	3700	4200
B	mm	970	1165	1315	1650	1880	2370
C	mm	1300	1665	1940	2220	2300	2400
D	mm	1810	2050	2370	2665	3200	4180

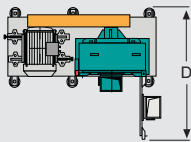

### Design with lateral product discharge

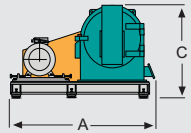
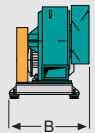

A	mm	2000	2850	3100	3500	3950	4500
B	mm	970	1165	1315	1650	1880	2370
C	mm	1300	1665	1940	2220	2300	2400
D	mm	1810	2050	2370	2665	3200	4180

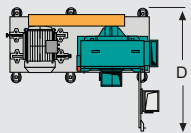



## The PALLMANN Group of Companies

The PALLMANN Group of companies is a leading manufacturer for size reduction machines and systems for the process industries. PALLMANN Maschinenfabrik develops and manufactures machines and complete systems according to customer requirements or as standard solutions for the preparation of almost any material as well as recycling products. In its headquarters in Zweibrücken, PALLMANN operates one of the world's largest research and technology centers as well as a training- and service center. More than 130 different test machines are available for the preparation of a wide variety of materials. A downstream laboratory analysis of the test material as well as the preparation on a production scale is possible. In addition to the manufacturing facilities in Europe, North- and South America, the PALLMANN group of companies operates a world-wide spare parts- and service network.



## The PALLMANN Program

### Engineering and Service:

Design and manufacturing  
Research and development  
Production scale testing  
Laboratory analysis  
Worldwide service  
Spare parts  
Controlling  
Process Control  
Installation & Start-up  
Overhaul & Repair

### System solutions for:

Pulverizing  
Granulating  
Agglomerating  
Recycling

### Products:

Agglomerators  
Pulverizing Systems  
Disc Mills  
Turbo Mills  
Pin Mills  
Laboratory Mills  
Universal Mills  
Complete Grinding Systems  
Knife Mills  
Profile Shredders  
Rubber Granulators  
Pipe Crushers  
Air-Swept Mills  
Impact Mills  
Industrial Granulators  
Cryogenic Grinding Systems

PALLMANN Industries Inc.  
36 Atlantic Way  
Clifton NJ 07012  
USA  
Phone +1 973 471 9773  
Fax +1 973 471 7152  
E-mail: [info@pallmannindustries.com](mailto:info@pallmannindustries.com)  
<http://www.pallmannindustries.com>

PALLMANN do Brasil Ind. e Com. Ltda.  
Av. Presidente Juscelino, 11 56  
09950-370 Diadema S.P.  
Brasil  
Phone +55 11 4075 3044  
Fax +55 11 4075 4968  
E-mail: [pallmann@pallmann.com.br](mailto:pallmann@pallmann.com.br)  
<http://www.pallmann.com.br>

PALLMANN Moskau Office  
Leninskij prospekt dom 158  
Hotel "Salut", Office Nr. 2053-2054  
117571 Moskau  
Russland  
Phone +7 095 232 15 21  
Fax +7 095 232 15 22  
E-mail: [Vitali.Krohmer@pallmann.de](mailto:Vitali.Krohmer@pallmann.de)

PALLMANN Beijing Representative Office  
Unit 13, 6th Floor of Tower A  
Beijing Cofco Plaza  
No.8, Jianguomennei Dajie, Dongcheng District  
Beijing, China  
Phone +86 10851 16826  
Fax +86 10851 16825  
E-mail: [info@pallmann.com.cn](mailto:info@pallmann.com.cn)

PALLMANN Maschinenfabrik GmbH & Co.KG  
Wolfslochstraße 51  
66482 Zweibrücken  
Germany  
Phone +49 6332 802 0  
Fax +49 6332 802 521  
E-mail: [process@pallmann.de](mailto:process@pallmann.de)  
<http://www.pallmann.de>